

SHAPES and SIZES: SOME ENGINE DIMENSIONS

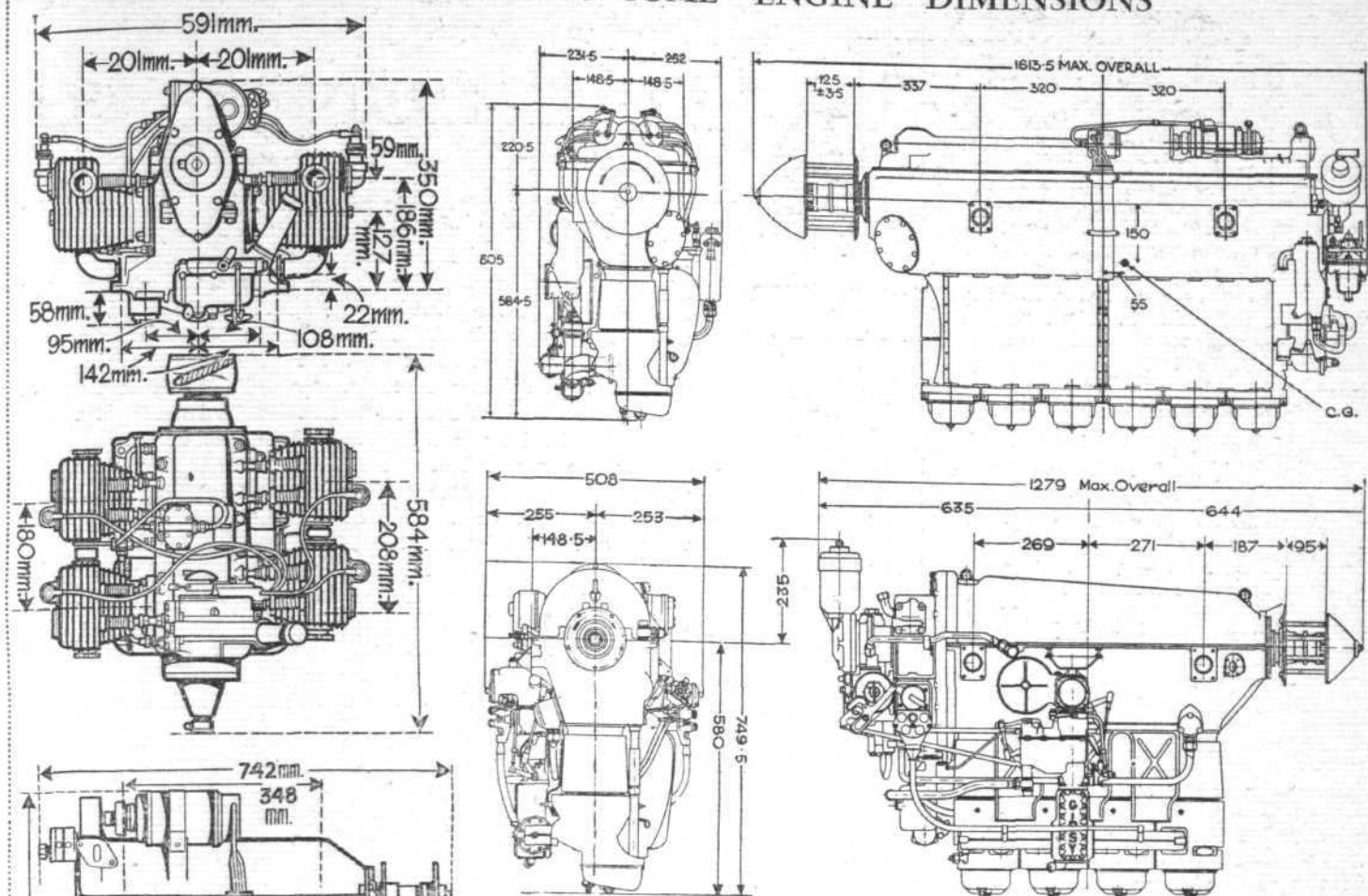

(Top right) The 205 h.p. Gipsy Six Series II and, below it, the 140 h.p. Gipsy Major II; both these engines can drive the 1,000 size D.H. v.p. airscrew. (Top left) The four-cylinder 40 h.p. Coventry Victor Neptune III.

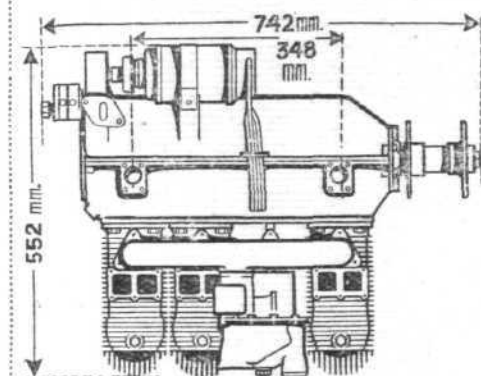

60 h.p. two-stroke Caunter C.

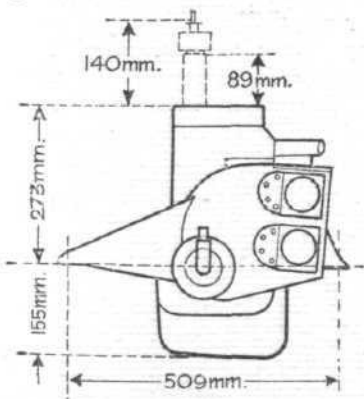

32 h.p. Chilton Carden-Ford.

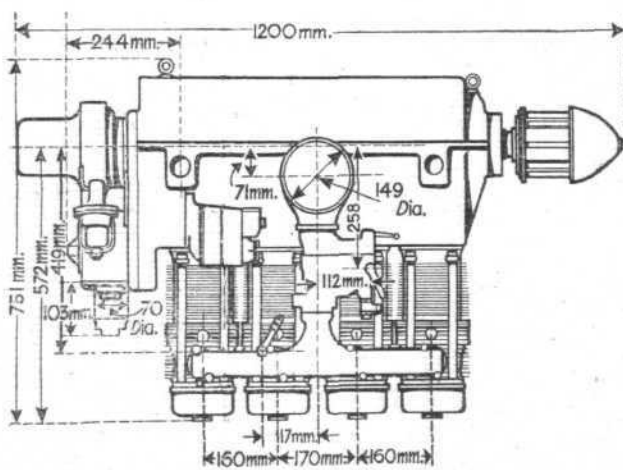

The 90 h.p. Cirrus Minor and, above it, the Cirrus Major 150.

